

IC-35-G **Industrial Crane**

The IC-35 is small in size with big crane features. This machine is a customer favorite because of its legendary reliability. It's tight turning radius is perfect for maneuverability in space-constrained work sites.

Capacity

8,000 lbs. (3,620 kg)

Sheave Height

33' 4" (10.2 m)
(with boom extension)

Horizontal Reach

27' 2" (8.28 m)
(with boom extension)

Height

6' 6" (1.98 m)

Width

5' (1.52 m)



IC-35-G

SPECIFICATIONS

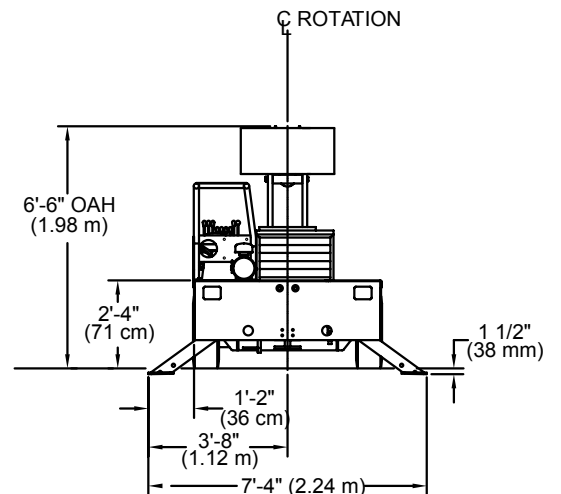
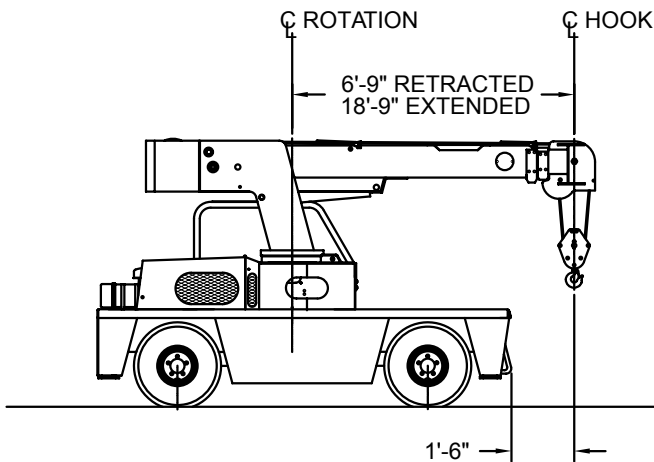
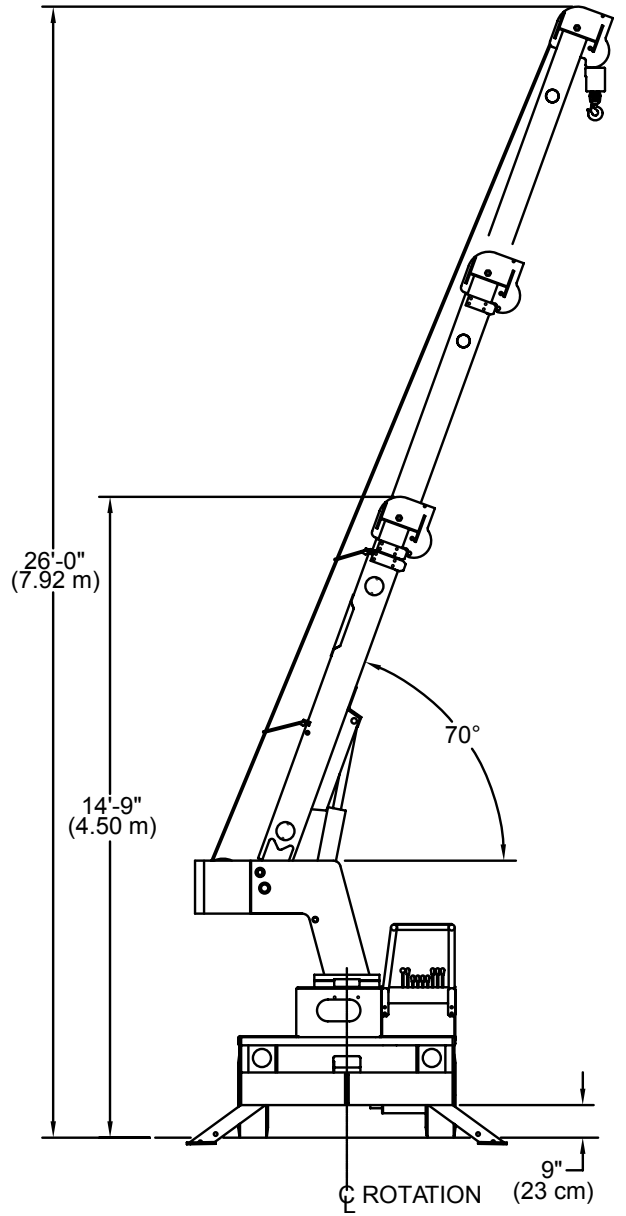
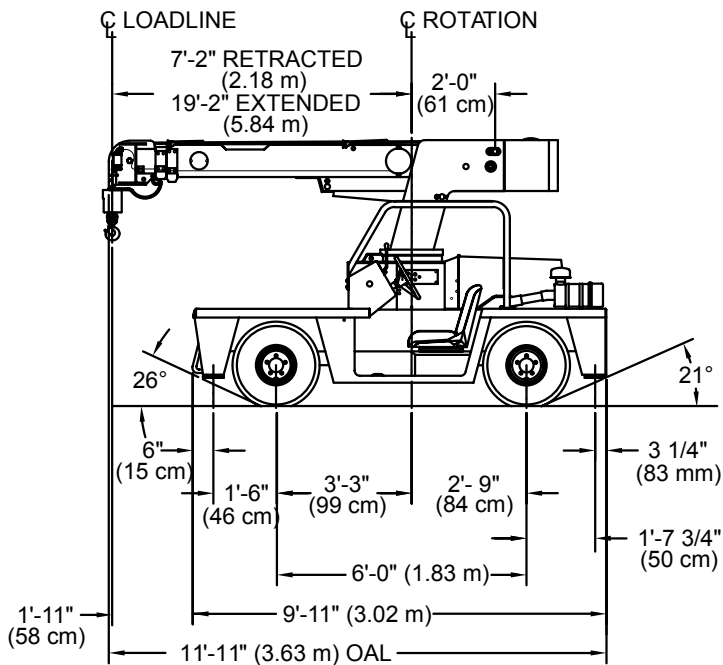
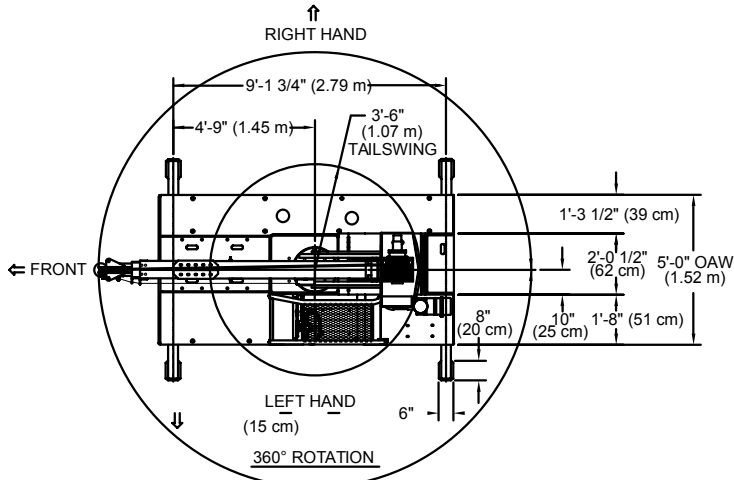

GENERAL

	ROTATION	ELEVATION	EXTENSION
Boom Movement	Continuous	0° to 70°	12' (3.66m)
Boom Speeds	1.5 RPM	17 sec.	32 sec.
Weight Total	7,860 lbs. (3,565 kg.)		
Travel Speed	0 to 10 mph (16 km/h)		
Drawbar Pull	2,120 lbs. (960 kg.)		
Gradeability	30%		

ENGINE

Make	Kubota	Kubota
Model	1.6L EFI	1.8L D1803 (T4F)
Type	Dual Fuel	Diesel
Cylinder	4	3
Displacement	1.6L	1.8L
HP @ Gov. Speed	44HP (35kW)	50HP (37kW)
Fuel Tank Capacity	13.5 gal. (51L)	13.5 gal. (51L)

HYDROSTATIC PUMP

Piston type, direct driven from engine crankshaft.
Maximum flow 34 GPM (120 L/min).
Maximum pressure 4,000 psi (275 bar).

AXLES

FRONT
Channel shaped structure houses torque hubs, brakes and hydraulic drive motors. Axle oscillates a total of 1 1/2" (38 mm).
REAR
Fixed rigid to frame.

STEERING

Full hydraulic steering unit controls 2 1/2" (63 mm.) steering cylinder attached to rear axle.

BRAKES

Primary braking from hydrostatic transmission. Foot-actuated disc brake attached to each torque hub for additional braking in some conditions. Parking brake switch locks brakes to hold crane when not being driven.

TIRES

FRONT
7.5 x 10 pneumatic, 16-ply, 145 PSI, (1000 kPa)
REAR
7.5 x 10 pneumatic, 16-ply, 145 PSI, (1000 kPa)

CHASSIS

CARGO DECK
9 sq. ft. (2.7m) of deck area. 6,000 lbs. (2,720 kg) capacity on deck when load is centered over or between axles.

OUTRIGGERS
Four hydraulic outriggers of box-beam construction. Independent controls for each. Hydraulic cylinders are equipped with direct-connected holding valves.

HEADLIGHT & TAILLIGHT GRILLES
Welded steel protective grilles for headlights and taillights.

LIFTING RINGS
Lifting rings at each corner of cargo deck so sling can be attached for lifting crane.

FRONT PULLING EYE
Mounted on front bumper.

OPERATOR COMPARTMENT

Provides one-position access to all chassis & crane functions. Includes adjustable operator's seat, retracting seat belts, fire extinguisher & bubble level.

ELECTRICAL (12-VOLT SYSTEM)

LIGHTING PACKAGE
One pair headlights and taillight.

DISPLAY
Fuel, voltmeter, oil pressure, and water temperature gauges, hydraulic oil temperature gauge and hourmeter.

BACK-UP ALARM
Provides pulsating sound from 97dB alarm when transmission is in reverse.

OUTRIGGER ALARM SYSTEM
112 dB alternating two-tone alarm is activated when "outrigger down" controls are operated.

HYDRAULIC

TANDEM PUMP mounted to rear of hydrostatic piston pump. Delivers 6 GPM (23 L/min) at 2,600 PSI (179 bar) for boom circuits and 17 GPM (64 L/min) at 2,500 PSI (155 bar) for hoist circuit. System protected by relief valves. Hydraulic oil reservoir has 14 gallon (53L) capacity.

BOOM ASSEMBLY

THREE-SECTION BOOM ASSEMBLY
equipped with bearing pads, double-acting hydraulic cylinders extends boom. The primary extension cylinder and the double-acting boom elevation cylinder are equipped with direct connected holding valves. Boom angle indicator on side of boom.

BOOM ROTATION
Heavy-duty ball bearing rotation gear with external teeth. Rotation is powered by hydraulic motor & worm gear drive.

BOOM HOIST
Turret mounted planetary gear hoist hydraulically powered with a bare drum line pull of 5,000 lbs. (2,268 kg) & a line speed of 86 FPM (26 m). Hoist includes 85 ft. (26 m) of 3/8 in. (9.5 m) wire rope, downhaul weight, swivel hook and sheave block for 2-part line.

ANTI-TWO-BLOCK DEVICE
Prevents damage to hoist rope and/or crane components from pulling load hook against tip.

RATED CAPACITY LIMITER
Warns operator of impending overload with audible & visual signals. Prevents overload by stopping boom functions that cause overloads.

CONSULT THE IC-35-G ENGINEERING SPEC FOR ADDITIONAL INFORMATION.

Main Features

RATED CAPACITY LIMITER
Standard

CAPACITY ON OUTRIGGERS
8,000 lbs. (3,620 kg)

PICK AND CARRY CAPACITY
up to 6,700 lbs. (3,040 kg)

HEIGHT
6' 6" (1.98 m)

WIDTH
5' (1.52 m)

BOOM ROTATION
360° Continuous

SHEAVE HEIGHT
up to 33' 4" (10.2 m)

HORIZONTAL REACH
up to 27' 2" (8.28 m)

TIGHT TURNING RADIUS

REAR WHEEL STEER
Standard

FRONT WHEEL DRIVE
Standard

**FULLY HYDRAULIC CONTROLS FOR
SMOOTH, PRECISE OPERATIONS**

**INDEPENDENT OUTRIGGER
CONTROLS**

DUAL FUEL OR DIESEL AVAILABLE

Options

TIRE

Solid Rubber Tires

For applications where hazardous ground conditions exist.

Solid Rubber Tires - Non Marking

Foam Filling of Tires

Spare Tire & Wheel - Pneumatic

Spare Tire & Wheel - Solid Rubber

Spare Tire & Wheel - Solid Rubber, Non Marking

Foam Filling of Spare Tires

CHASSIS OPTIONS

Auxiliary Winch

Mounted behind the front bumper, hydraulically driven with control in operator's console - 3,000 lbs (1,360 kg) @ 20 FPM (6m/min).

Pintle Hook - Rear

Holland "T-60-A" pintle hook mounted on rear of frame. 5-ton capacity.

Lifting Sling

Three leg lift sling to attach to Lifting Rings.

Rearview Mirrors

One mounted on right-hand deck stake and one mounted on left-hand deck stake. Pivots out of the way for obstacles.

OPERATOR COMPARTMENT

All Weather Cab

Rigid-mounted canopy section and removable hinged door with safety glass. Cab door adds 4 in. (102 mm) to crane on operator's side. Includes heater, electric windshield wiper, one sliding glass window in the door, & one fold out window in rear. Defroster fan & dome light included.

Cab Heater Only

Heater with two-speed fan for units without All Weather Cab.

Operator Guard

Tubular steel weldment with heavy expanded steel mesh top section for units without All Weather Cabs.

Floor Mat

Vinyl mat with foam backing.

ELECTRICAL

Strobe Lights

Yellow strobe light mounted on each side of turret weight box.

Boom Work Lights

One work light mounted to boom to light boom tip and one work light mounted to turret to light ground under boom tip. Includes switch in operator's compartment.

RCL Light Bar

3 color light bar for external indication of load status

EXTRA LONG WIRE ROPE

140 ft. (42.6m), boom stowable

BOOM ATTACHMENTS

Boom Extension

8 foot (2.4 m), boom stowable.

Boom Extension, Offset

8 foot (2.4 m), boom stowable. Boom extension is offsettable to 3 different positions; 0° (in line), 15 degree and 30° offset.

Searcher Hook - Nose Mount

2,000 lb (907kg) capacity. Swivel hook with spring latch hangs from support structure projecting outward from boom tip.

Broderson Cranes are manufactured to ISO 9001:2015 certified standards and have a market leading reputation for quality and reliability. Broderson Cranes are engineered for operating efficiency and are easy to operate and maintain.

An extensive network of full-service dealers offer parts and service support by factory-trained technicians.

For additional options or special equipment not listed, please consult your dealer salesperson or contact Broderson Manufacturing Corp.

BRODERSON[®]
Manufacturing Corp.
14741 West 106th Street
Lenexa, KS 66215 USA

(913) 888-0606
www.BMCcranes.com

Dimensions and values shown
are for reference purposes
only. Specifications subject
to change.

